

LR6

6" Downlight Module

Product Description

The LR6 is a downlight module for new construction and retrofit that installs easily in most standard six inch recessed IC or non-IC housings. The LR6 generates white light with LED in a new way that enables an unprecedented combination of light output, high efficacy, beautiful color, and affordability. U.S. Patent # 7,213,940 issued. Numerous patents pending from Cree and other manufacturers.

Performance Summary

- Nominal delivered light output = 650 lumens
- Nominal input power = 12 Watts
- CRI 92
- CCT = 2700k or 3500K
- Dimmable to 25%

Ordering Information

- **LR6** 120V, Incandescent Color (2700K), Edison Base (STANDARD)
- **LR6-GU24** 120V, Incandescent Color (2700K), GU24 Base
- **LR6C** 120V, Neutral Color (3500K), Edison Base
- **LR6C-GU24** 120V, Neutral Color (3500K), GU24 Base

LR6-GU24

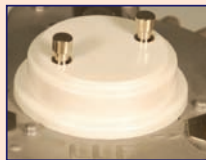

Accessories - Reference individual accessory spec sheets for more detail

Accessory Trims

- **LT6A** - Diffuse anodized trim
- **LT6AW** - Wheat diffuse anodized trim
- **LT6AP** - Pewter diffuse anodized trim
- **LT6AB** - Black diffuse anodized trim
- **LT6WH** - Smooth white trim
- **LT6AG** - Graphite diffuse anodized trim
- **LT6AM** - Mocha diffuse anodized trim

Housings

- **RC6** - New construction 12W recessed housing
- **RR6** - Retrofit 12W recessed housing
- **SC6** - Surface mount cylinder
- **C6** - Conversion kit for 6" pan-style housings



LR6



LR6C

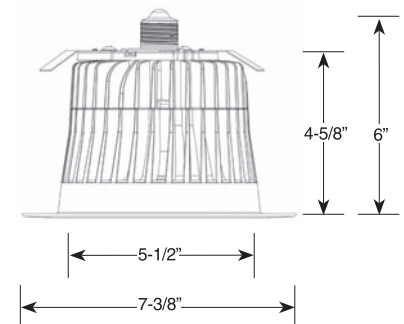

LR6

6" Downlight Module

Specifications and Features

Light Emitting Diodes

- Cree proprietary technology delivers uniform, high-quality, white light
- Designed to last 50,000 hours - maintains at least 70% of initial lumen output
- Active color management system maintains color consistency

Construction

- Durable die-cast aluminum upper housing, lower housing, and upper cover
- Integrated thermal management system conducts heat away from LED and transfers it to the surrounding environment. LED junction temperatures stay below specified maximums when installed in attic insulation with temperatures exceeding 60 degrees Celsius.

Optical System

- Proprietary optical system utilizes a unique combination of reflective and refractive optical components to achieve a uniform, comfortable appearance. Pixelation and direct view of uncomfortable LEDs is eliminated.
- White Lower Reflector balances brightness of refractor with the ceiling to create comfortable high-angle appearance. Works with refractor to deliver an optimized distribution that illuminates walls and vertical surfaces increasing the sense of spaciousness.

Electrical System

- Integral, high efficiency driver and power supply. Power factor > 0.95 Input voltage = 120V, 60Hz
- Dimmable to 25% with some incandescent dimmers (reference www.creeLLS.com for recommended dimmers)

Regulatory

- Tested and certified to UL standards. Suitable for damp locations.
- Utilize GU-24 base for new construction projects in California or other areas where high efficacy line voltage sockets are required
- Exceeds California Title-24 high efficacy luminaire requirements

Photometry

LR6 – 120V, Incandescent Color (2700K), Edison Base (STANDARD)
Lighting Sciences Inc. Certified Test #22226

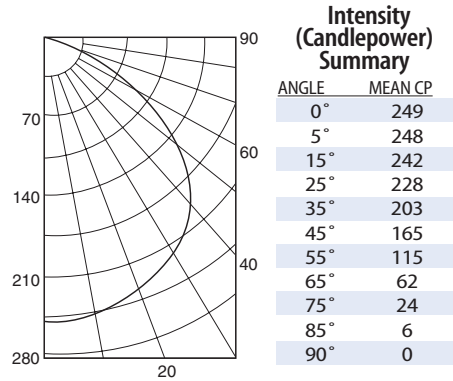

Zonal Lumen Summary

ZONE	LUMENS	%LAMP	%FIX
0° - 30°	196	30.39	30.39
0° - 40°	323	49.94	49.94
0° - 60°	553	85.35	85.35
0° - 90°	647	100.00	100.00

Installation

- Designed to easily install in standard 6" downlight housings from numerous manufacturers*
- Quick install system utilizes a unique retention feature. Attach socket to module. Adjust module to ready position and slide into housing. Rotate module 1/4 turn to the right to lock in place

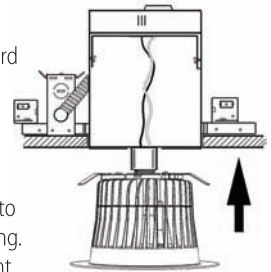

*Reference www.CreeLLS.com for housing compatibility

Application Comparison

Room

	6' x 6' Spacing		5' x 5' Spacing		4' x 4' Spacing	
	Workplane Illuminance	Wall Illuminance	Workplane Illuminance	Wall Illuminance	Workplane Illuminance	Wall Illuminance
LR6	15.1	8.0	19.9	10.7	27.2	15.4
65W BR30 White Baffle	14.0	6.3	18.7	8.6	26.1	12.6
18W CFL White Baffle	15.5	7.9	20.8	10.6	28.7	15.4
50W PAR30 White Baffle	16.7	4.1	22.9	5.7	34.1	8.6

Notes:

Average initial illuminance in footcandles, reflectances = 80/50/30, workplane height = 2.5', ceiling height = 9', Nine lights per room. Room sizes = 18x18; 15x15; 12x12

Hallway

	6' Spacing		8' Spacing		10' Spacing	
	Workplane Illuminance	Wall Illuminance	Workplane Illuminance	Wall Illuminance	Workplane Illuminance	Wall Illuminance
LR6	12.6	6.8	9.6	5.2	7.6	4.0
65W BR30 White Baffle	12.0	5.3	9.1	4.0	7.2	3.2
18W CFL White Baffle	13.0	6.6	10.1	5.1	7.9	4.0
50W PAR30 White Baffle	14.6	3.1	11.2	2.6	9.1	1.8

Notes:

Average initial illuminance in footcandles, reflectances = 80/50/30, workplane height = 2.5', ceiling height = 9', Six lights per hall, width = 6'



LED Lighting Solutions

Cree LED Lighting Solutions

Morrisville • NC • 27560 • USA

1-919-287-0470

Fax 1-919-991-0730

www.CreeLLS.com